

**INSTALLATION NOTES:**

1. SHIM AS REQUIRED TO ACHIEVE A PLUMB AND SQUARE ISNTALLATION WITH LOAD BEARING SHIM(S). MAXIMUM ALLOWABLE SHIM STACK TO BE 1/4". SHIM WHERE SPACE OF 1/16 OR GREATER OCCURS. SHIM(S) SHALL BE CONSTRUCTED OF HIGH DENSITY PLASTIC OR BETTER.
2. MINIMUM EMBEDMENT AND EDGE DISTANCE EXCLUDE WALL FINISHES, INCLUDING BUT NOT LIMITED TO STUCCO, FOAM, BRICK VENEER AND SIDING.
3. INSTALLATION ANCHORS AND ASSOCIATED HARDWARE MUST BE MADE OF CORROSION RESISTANT MATERIAL OR HAS A CORROSION RESISTANT COATING.
4. INSTALLATION ANCHORS SHALL BE INSTALLED IN ACCORDANCE WITH ANCHOR MANUFACTURER'S INSTALLATION INSTRUCTIONS AND ANCHORS SHALL NOT BE USED IN SUBSTRATES WITH STRENGTHS LESS THAN THE MINIMUM STRENGTH SPECIFIED BY THE ANCHOR MANUFACTURER.
5. INSTALLATION ANCHOR CAPACITIES FOR PRODUCTS HEREIN ARE BASED ON SUBSTRATE MATERIALS WITH THE FOLLOWING PROPERTIES:
  - A. WOOD - MINIMUM SPECIFIC GRAVITY OF 0.55.
  - B. STEEL - MINIMUM 20 GA. STEEL , MINIMUM Fy = 33 KSI.
6. FOR FIN INSTALLATION INTO 2X WOOD BUCK OR FRAMING, USE ONE #8 WOOD SCREW, TYPE INSTALLATION ANCHOR PER LOCATION OF SUFFICIENT LENGTH TO ACHIEVE A MINIMUM 1 1/2" EMBEDMENT AND SHALL MAINTAIN A MIN. EDGE DISTANCE OF 3/4 IN.
7. FOR FIN INSTALLATION THROUGH METAL STUD USE #8 SMS OR SELF DRILLING SCREWS OF SUFFICIENT LENGTH TO ACHIEVE 3 THREADS MINIMUM PENETRATION BEYOND METAL STRUCTURE. METAL ANCHORS SHALL MAINTAIN A MINIMUM EDGE DISTANCE OF 3/4 INCH.

**GENERAL NOTES:**

1. THE PRODUCT SHOWN HEREIN IS DESIGNED AND MANUFACTURED TO COMPLY WITH THE CURRENT EDITION FLORIDA BUILDING CODE (FBC) EXCLUDING HVHZ AND HAS BEEN EVALUATED ACCORDING TO THE FOLLOWING:
  - AAMA/WDMA/CSA 101/1.S.2/A440-08
2. ADEQUACY OF THE EXISTING STRUCTURAL CONCRETE/MASONRY AND 2X FRAMING AS A MAIN WIND FORCE RESISTING SYSTEM CAPABLE OF WITHSTANDING AND TRANSFERRING APPLIED PRODUCT LOADS TO THE FOUNDATION IS THE RESPONSIBILITY OF THE ENGINEER OR ARCHITECT OF RECORD FOR THE PROJECT OF INSTALLATION.
3. 2X BUCKS (WHEN USED) SHALL BE DESIGNED AND ANCHORED TO PROPERLY TRANSFER ALL LOADS TO THE STRUCTURE. BUCK DESIGN AND INSTALLATION IS THE RESPONSIBILITY OF THE ENGINEER OR ARCHITECT OF RECORD FOR THE PROJECT OF INSTALLATION.
4. 2X WOOD STUDS SHALL BE ATTACHED TO FULL LENGTH OF THE FRAME WHEN USED INSIDE METAL FRAMING AS STIFFENERS, WOOD STIFFENERS SHALL BE DESIGNED AND ANCHORED TO PROPERLY TRANSFER ALL LOADS OF THE STRUCTURE. STIFFENER DESIGN AND INSTALLATION IS THE RESPONSIBILITY OF THE ENGINEER OR ARCHITECT OF RECORD FOR THE PROJECT OF INSTALLATION.
5. THE INSTALLATION DETAILS DESCRIBED HEREIN ARE GENERIC AND MAY NOT REFLECT ACTUAL CONDITIONS FOR A SPECIFIC SITE. IF SITE CONDITIONS CAUSE INSTALLATION TO DEVIATE FROM THE REQUIREMENTS DETAILED HEREIN, A LICENSED ENGINEER OR ARCHITECT SHALL PREPARE SITE SPECIFIC DOCUMENTS FOR USE WITH THIS DOCUMENT.
6. APPROVED IMPACT PROTECTIVE SYSTEM IS REQUIRED TO PROTECT THIS PRODUCT IN AREAS REQUIRING IMPACT RESISTANCE.
7. WINDOW FRAME MATERIAL: PVC
8. GLASS MEETS REQUIREMENTS OF ASTM E1300 GLASS CHARTS.
9. DESIGNATIONS:  
O: FIXED PANEL

**CROFT, LLC**  
**SERIES 21 FIXED WINDOW**

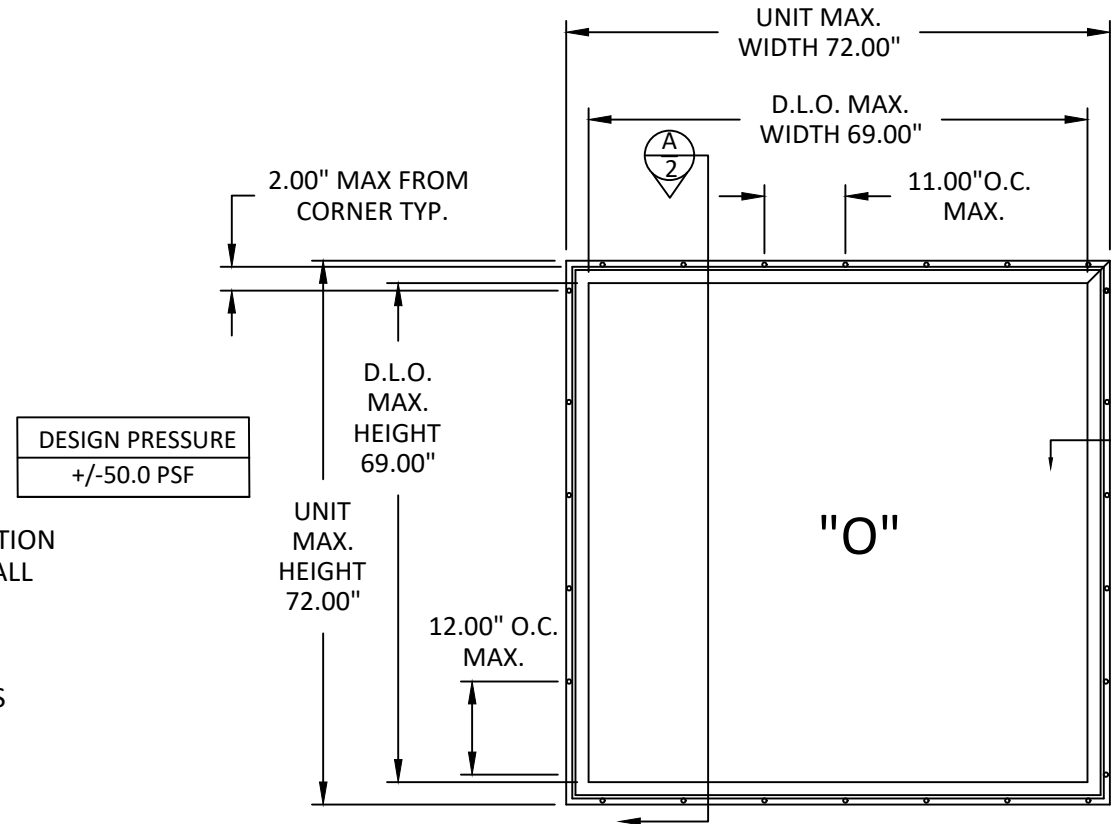

**ELEVATION AND ANCHOR LAYOUT**

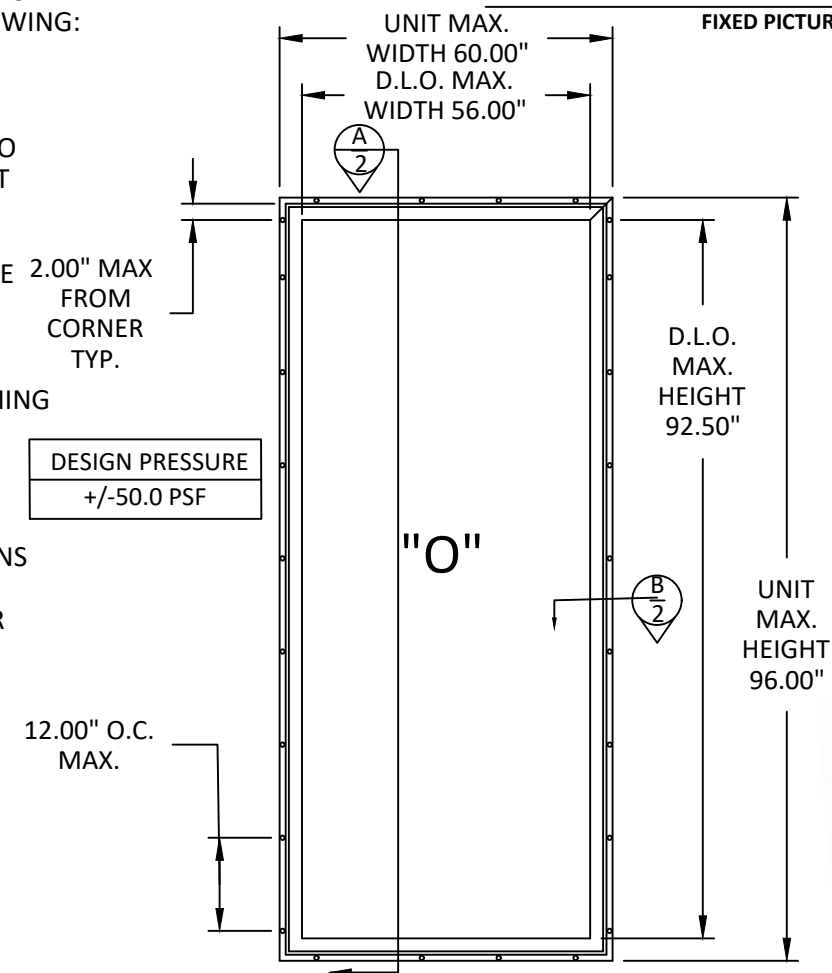

**ELEVATION AND ANCHOR LAYOUT**  
FIXED PICTURE WINDOW



Title: **SERIES 21 FIXED WINDOW**  
NOTES AND ELEVATION  
**CROFT, LLC.**  
1800 NORTH CLARK AVENUE  
MAGNOLIA, MS 39652  
PH: 601-684-6121 FX: 601-783-3188

REVISIONS		DATE	BY
A.	5TH EDITION 2014 FBC REVISION	2/11/16	LS
B.	7TH EDITION 2020 FBC REVISION	AC 8/17/21	AC

11/14/12  
DWN BY: J.BITZ  
CHK BY: --  
SCALE: NONE

DRAWING #: **0020-952**

SHEET: **1 OF 2**

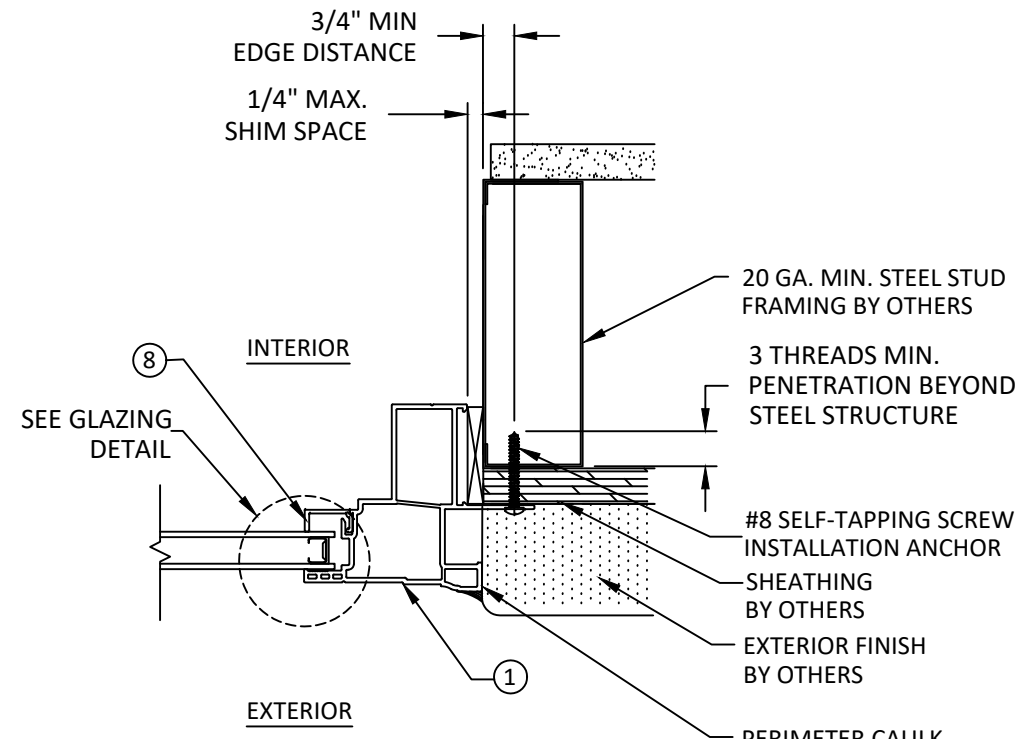
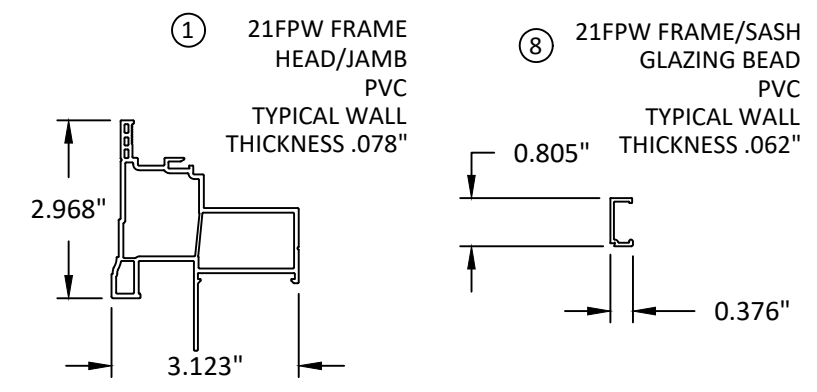
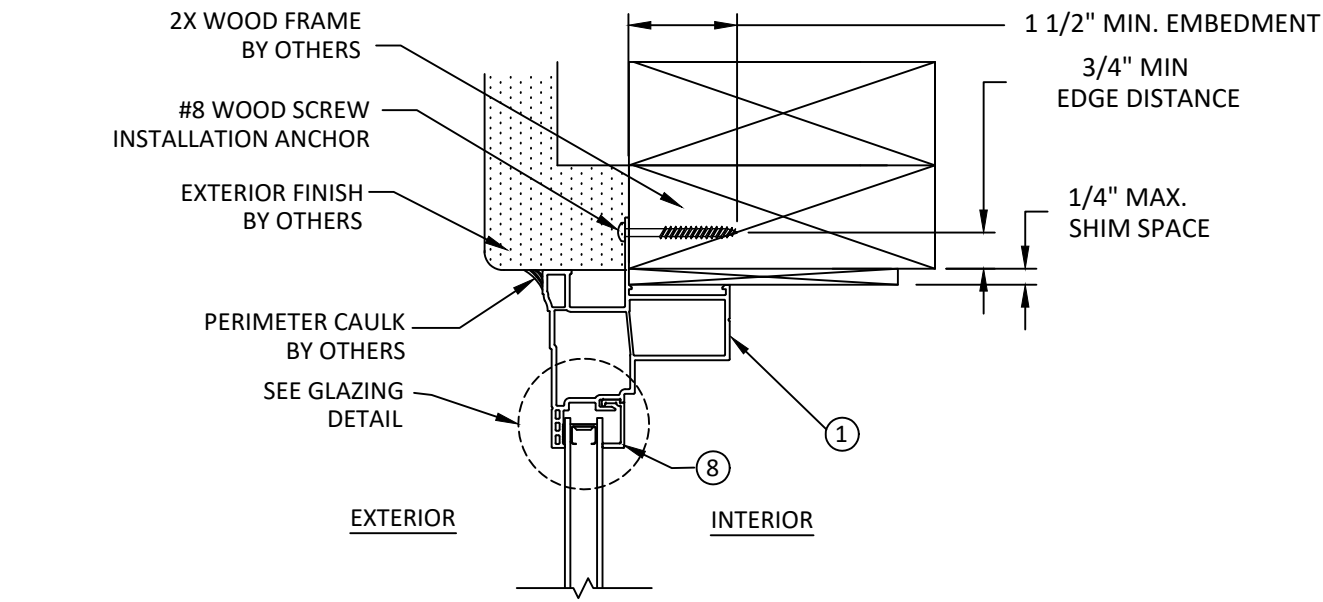

**B**  
**2** HORIZONTAL SECTION  
JAMB - STEEL STUD FRAME  
NAIL FIN

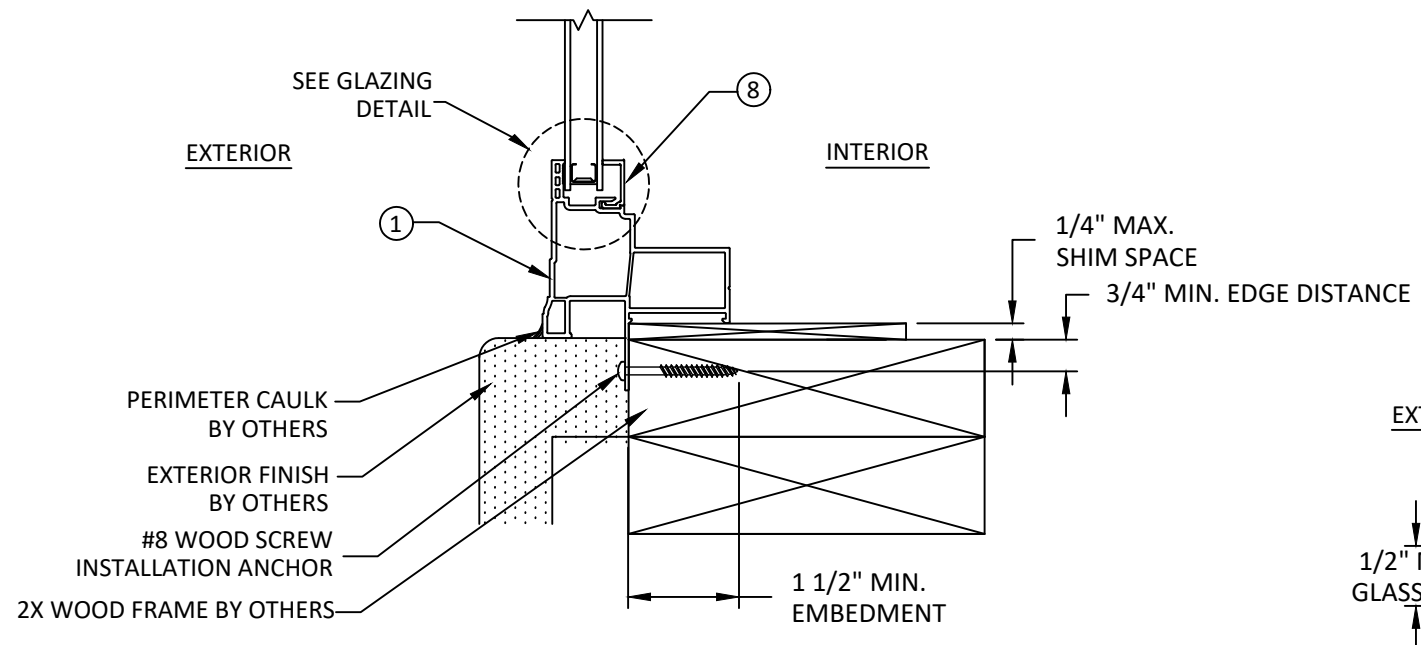

**A**  
**2** VERTICAL SECTION  
SILL - 2X WOOD FRAME  
NAIL FIN

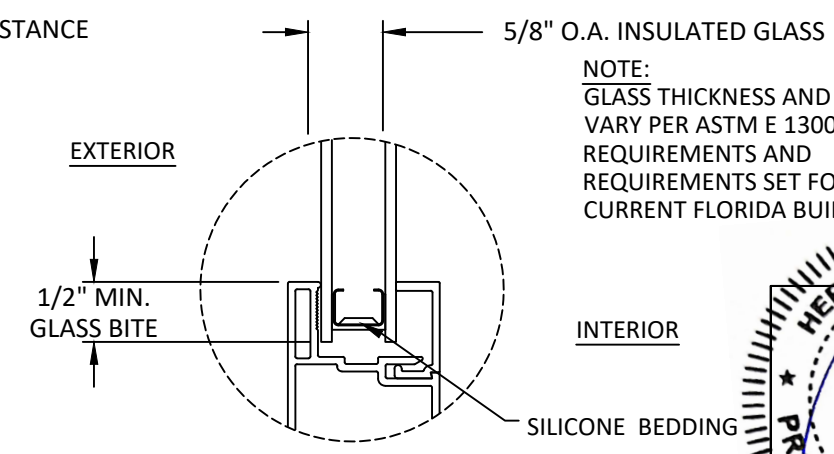

**GLAZING DETAIL**

NOTE:  
GLASS THICKNESS AND TYPE MAY VARY PER ASTM E 1300 GLASS CHART REQUIREMENTS AND REQUIREMENTS SET FORTH IN THE CURRENT FLORIDA BUILDING CODE.

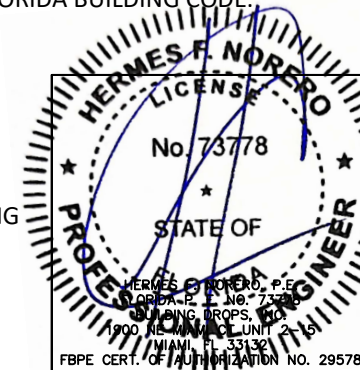

Title:  
**SERIES 21 FIXED WINDOW**  
X-SECTIONS & GLAZING DETAIL  
CROFT, LLC.  
1800 NORTH CLARK AVENUE  
MAGNOLIA, MS 39652  
PH: 601-684-6121 FX: 601-783-3188

REVISIONS		NO.	DESCRIPTION	BY	DATE
A	7TH EDITION 2020 FBC REVISION	AC	08/27		

DRAWING #:  
**0020-952**

SHEET:  
**2 OF 2**